



# AT810: A New Benchmark for Silicon Tuners

*Y. Mathys, C. Eichrodt, V. Arbet-Engels and M. Lattuada*

## Summary

Abilis Systems introduces the industry's lowest power, lowest system cost (BOM) and highest performance silicon based tuner (AT810) for consumer products e.g. Set Top Box, PCTV, Portable TV, DVD Players, Automotive Media applications.

The ATON™ AT810 is a direct conversion, highly integrated, single-chip tuner optimized for DVB-T, DVB-T2, CMMB, DTMB/GB 20600-2006, and ISDB-T full-segment applications.

Featuring completely automated radio control and virtually no external components, the AT810 offers unprecedented levels of performance, power consumption and size matching the most stringent system requirements.

## Introduction

The best examples among the latest generation of silicon digital TV tuners achieve the performance standards set by traditional superhet CAN tuners while delivering substantial savings in size, power and cost.

Using low cost digital compatible CMOS processes, the leading devices have eliminated almost all external components and at the same time improved the all-important function of selectivity, a common weakness of first generation silicon tuners compared to conventional superhets.

Receiver selectivity is becoming even more important as the analog switch off around the world releases some former TV spectrum for other uses - the so-called digital dividend.

At Abilis, we are introducing our third generation silicon tuner, the AT810 designed to exceed the latest NorDig, D-Book and ARIB specifications. Offered in an attractive small footprint 4x4mm QFN package, it provides unprecedented selectivity performance whilst setting a new standard for low power at only 250mW maximum power dissipation. The highly integrated AT810 requires only two low cost inductors (for matching) and a few capacitors (for decoupling) plus a crystal required by way of external components.

### AT810 Product Highlights

Frequency Range (cont.)	90MHz - 878MHz
Typical Noise Figure	5.4dB
Max. OFDM Input	0dBm
3rd Harmonic Suppression	60dB
ACR at (N+1)	40dB

This information contained herein is the exclusive property of Abilis Systems and shall not be distributed, reproduced, or disclosed in whole or in part without prior written permission. Subject to change without notice. Copyright © 2010 Abilis Systems Sarl. All other trademarks mentioned in this document are trademarks of their respective owners.

## DTT Market Trend

Digital Terrestrial TV (DTT) has been a fast growing digital television platform, enabling many households to access digital TV services for the first time. In many countries it is now the predominant television reception platform and the advent of High-Definition (HD) TV and 3D television will further add to its popularity.

With Analog Switch-Off (ASO) planned for between 2009 and 2015 across the world, and with national regulators having ensured almost universal coverage, the advent of DTT is also freeing up spectrum for new services. In Europe, for example, many countries have expressed interest in re-allocating the frequencies from 790MHz to 862MHz to mobile broadband services. In addition, the European Union is introducing new legislation to reduce power consumption of consumer products.

DTT standards are mostly based on wide band, multi-carrier OFDM modulation, such as DVB-T/T2 in Europe, ISDB-T in Japan, and DTMB/GB 20600-2006 in China.

The DTT market is growing rapidly, already reaching over 40 million units per year in the Set Top Box (STB) market alone, and has a high penetration rate in flat panel TV making a total of over 80-100 millions unit per year. In support of the growing demand, Consumer Electronics (CE) device manufacturers are looking for cost effective TV receivers, immune to interference from other TV signals, or from other services, and meeting the latest low power regulations.

## Receiver Selectivity Requirements

A receiver's selectivity can be defined as its ability to receive a wanted signal in a given frequency channel without being affected by other signals present at its input.

Interferers may lie in adjacent channels, in nearby channels, or in far-off channels, and a receiver uses different mechanisms to minimize its response to these three categories.

We see a growing demand for improved receiver selectivity, especially for **nearby** channels, at  $N\pm 4$  and beyond. Notably, in the latest D-Book standard from the U.K. Digital Television Group (DTG) the Adjacent Channel Rejection (ACR) protection requirements have been increased significantly. We see a similar trend in the Japanese market.

Good selectivity also requires strong immunity to **far-off** signals such as GSM 1800/1900, 3G/LTE, DECT and WIFI, or at the other end of the spectrum, CB. These have a clear impact on receiver performance though they are not well captured by today's TV standards.

## Abilis' introduces its latest generation ZIF silicon tuner

The ZIF (zero IF) architecture was chosen for reasons of cost, simplicity and performance, and the ease of subsequent demodulation. The highly skilled architects at Abilis using an advanced CMOS process have made substantial improvements to the RF architecture itself, leading to better RF performance overall. Near-perfect switching permits a more sophisticated mixer topology, with minimal d.c. offsets, that in turn allows the mixer to be placed much closer to the RF input. The result is greatly improved signal handling. In addition, the use of CMOS permits an excellent noise figure to be achieved, together with very low LO phase noise.

# AT810: A New Benchmark for Silicon Tuners

In the AT810, the RF chain has been architected for best overall selectivity performance. By reducing the maximum gain ahead of the mixer to only 20dB, the receiver is able to support the presence of very large unwanted signals. The advanced mixer design, together with a tracking filter automatically programmed by the on-board microprocessor to follow the desired frequency, ensures that **far-off** signals such as GSM, DECT and WiFi, lying at the 3rd, 5th, etc., harmonics of the LO, are suppressed by around 60dB. When operating in the VHF band, UHF signals are similarly suppressed.

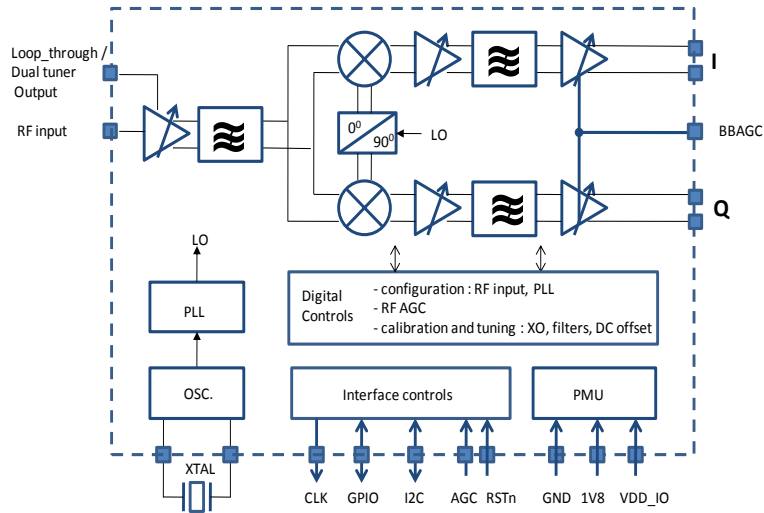

Following the mixer, a second order pre-filter having a 10MHz cut-off provides early attenuation of **nearby** signals, in fact those further than 6-7 channels away are completely suppressed. This filter approximates the function of the first IF filter in a superhet. A fifth order elliptic filter at baseband then takes care of the immediately **adjacent** channels.

The AT810 has excellent ACR performance meeting comfortably, with a very good margin, the most stringent system requirements, with no degradation at N+9. The figure below shows the ACR performance versus the latest D-Book standards where the AT810 largely exceeds the requirements and provides excellent selectivity against adjacent signals.

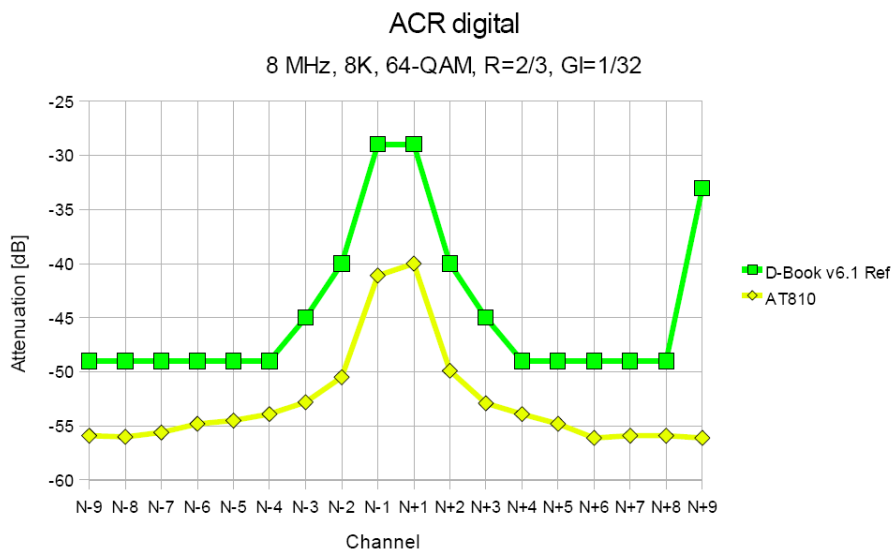

This information contained herein is the exclusive property of Abilis Systems and shall not be distributed, reproduced, or disclosed in whole or in part without prior written permission. Subject to change without notice. Copyright © 2010 Abilis Systems Sarl. All other trademarks mentioned in this document are trademarks of their respective owners.



# AT810: A New Benchmark for Silicon Tuners

The AT810 has a sophisticated AGC system which takes account of the frequency distribution of the total signal spectrum. Thus the gains of those blocks handling different frequencies are independently controlled in order to optimize overall performance.

Two switched input inductors at the antenna input itself provide low-Q selectivity, and serve to compensate for the spurious capacitance at the receiver front end. This filtering is particularly useful against low frequency interferers, such as FM radio and CB. Optimized for coverage of the UHF, and of the VHF bands (down to 90MHz), these, plus a few decoupling capacitors and a crystal, are the only external components needed.

Finally, a flexible integrated loop-through amplifier allows a standard loop through function to be provided, or it can be configured to support multi-tuner applications while maintaining an excellent noise figure.

The AT810 addresses the world-wide DTT growth by supporting most of the commonly used wide band, multi-carriers standards such as DVB-T/T2, ISDB-T, CMMB and DTMB/GB 20600-2006.

In summary, the AT810 offers the perfect combination of outstanding RF performance, low power, and low BOM making it an ideal product for the many opportunities arising from the world-wide growth of DTT.

## About Abilis Systems

Abilis Systems, a Kudelski Group company, is a semiconductor fables company providing integrated circuits for the Digital TV market. Abilis has pioneered the introduction of monolithic RF CMOS TV receivers and is providing leading RF modulators and Silicon tuners products for the consumer electronic markets.

Abilis Systems, headquartered in Geneva, Switzerland, also actively co-operates with sister companies of the Kudelski Group to develop complete hardware/software packages for highly secured conditional access systems. For more information, visit [www.abilis.com](http://www.abilis.com).