

Low Power CMOS Broadband Tuner

Abilis Systems' AT803C21QD is a 3.3 Volt, low power, high performance, single-chip CMOS, broadband tuner. This chip offers a cost-effective, low-power solution for high-performance analog and digital TV market. This highly integrated third generation silicon tuner covers a 48 MHz to 1 GHz RF input and converts to a 30 MHz to 60 MHz IF frequency. The 861 MHz to 1 GHz frequency range is supported with reduced performance.

The single-chip broadband tuner uses a double-conversion architecture, which eliminates tracking filters and their manually aligned coils. Two IF outputs are provided to support systems with multiple demodulators (e.g. one digital demodulator and one analog TV demodulator).

The AT803C21QD is designed to meet all Data Over Cable Service Interface Specification (DOCSIS), ATSC specifications for 8VSB, 64- and 256-Quadrature Amplitude Modulation (QAM) as well as the NorDig Unified 1.0.3 specifications for Coded Orthogonal Frequency Division Multiplexing (COFDM) for DVB-T.

The device is available in a Pb-free 64-pin quad leadless package (QFN).

Features

- Low power consumption (746 mW typical)
- Single 3.3 V supply operation
- Programmable power down mode with fast start-up
- Variable-gain Low-Noise Amplifier (LNA) with 40 dB gain control range
- Ability to switch between two external analog control voltages for LNA
- Two fully integrated frequency synthesizers
- Fully integrated tuned circuit Voltage Controlled Oscillators (VCOs)
- Fully integrated VCO varactors (requires only one external inductor)
- Second IF variable gain amplifier
- Flexible reference oscillator circuit (4.0 MHz to 28 MHz crystal)
- Reference oscillator buffer to drive additional tuners or modulators
- Choice of I²C or SPI interface control buses
- Internal self-diagnostic circuits
- Typical CTB of -63 dBc, CSO of -63 dBc and XMod of -55 dBc
- Typical noise figure of 7.0 dB
- Phase noise -89 dBc/Hz, typical @ 10 kHz offset

AT803C21QD

LOW POWER CMOS BROADBAND TUNER

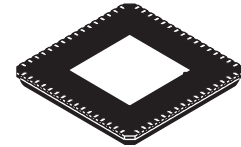

64-LEAD QFN PACKAGE
CASE 1606-01

ORDERING INFORMATION

Device	Temp. Range	Package	RoHS
AT803C21QD1C -2C (Tape & Reel)	0°C to +85°C	1606-01 64 QFN	yes

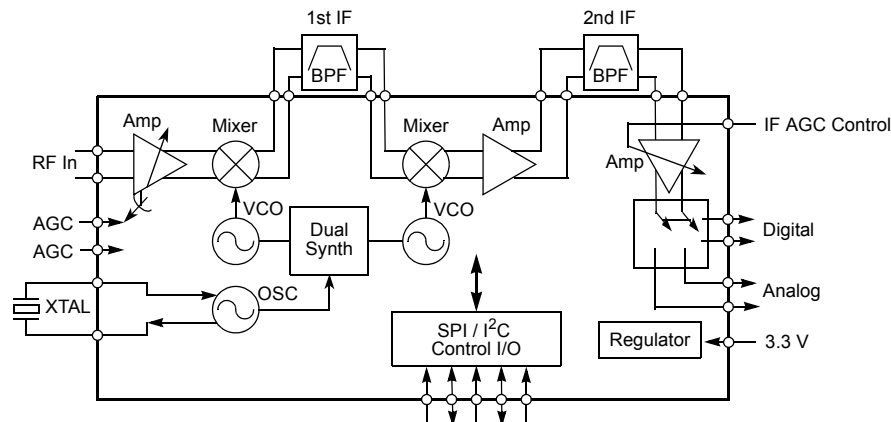

Figure 1. AT803C21QD Functional Block Diagram

OVERVIEW

Typical applications for the AT803C21QD include cable data modems, cable TV (CATV) set-top boxes (analog & digital), computer TV tuner cards (analog & digital), analog TV sets, digital terrestrial TV sets, digital terrestrial adapters, home DVD-R and DVR/PVR.

Figure 2 shows the major sections of the AT803C21QD. The input frequency range is 48 MHz to 1 GHz. RF signal reception from 861 MHz to 1 GHz is supported with reduced performance. The RF input signal enters the Low Noise Amplifier (LNA) after passing through the external diplex filter. The signal is then up converted to 1086 MHz (1086 MHz is an example frequency, not a limitation or recommendation) and passed through the first IF filter. This first IF SAW can be replaced with a lower cost filter (determined by application). The filtered signal is then routed back onto the chip where it is down converted to the second IF center frequency. This is fed to the second IF channel filter. The signal enters the IC again to go through the second IF variable gain output amplifier that gets an analog AGC control voltage from the demodulator.

The output can be switched between two output ports. This provides support for systems with multiple demodulators

(e.g. one digital demodulator and one analog TV demodulator).

Many of the amplifiers in the IC have programmable gain to balance the gain budget for a given application. Amplifier gains are typically set as part of the initialization sequence at power up, then do not need to be changed after that. All programming and configuration control is accomplished via an industry standard I²C or SPI interface bus.

Additional features of the AT803C21QD include:

- 3.3 V \pm 5% single supply operation
- Internal 1.8 V tracking regulator
- High linearity and reduced current
- Reduced gain roll off at high frequencies
- 40 dB gain control range in LNA, digitally or analog voltage controlled.
- 36 dB gain control range in IF, analog voltage controlled.
- Ability to switch between two control voltages for use with digital and analog demodulators
- Fully integrated VCO varactors (only one VCO inductor required)
- Reference crystal frequency range from 4.0 to 28 MHz

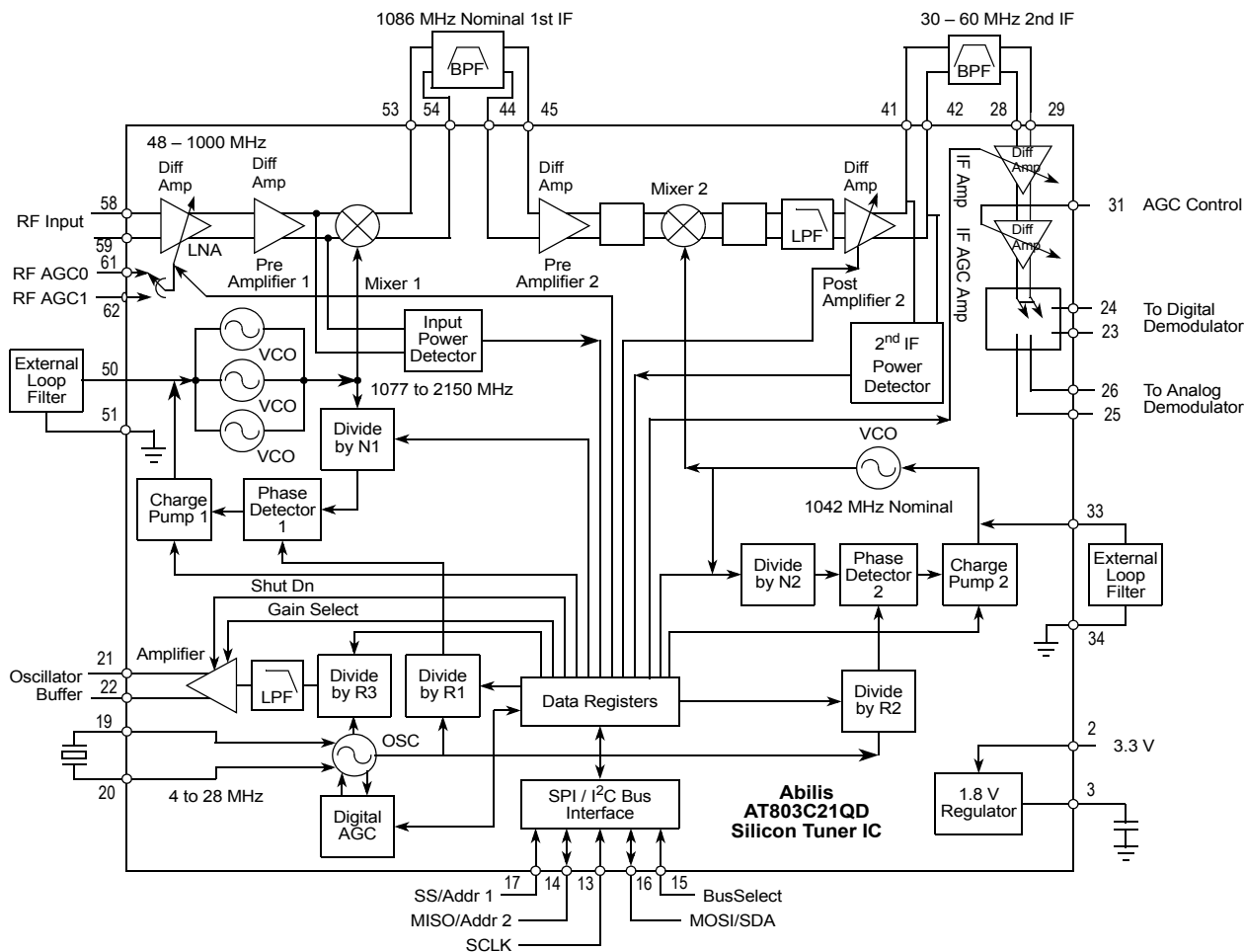

Figure 2. AT803C21QD Silicon Tuner IC Block Diagram